

Bomber Offense

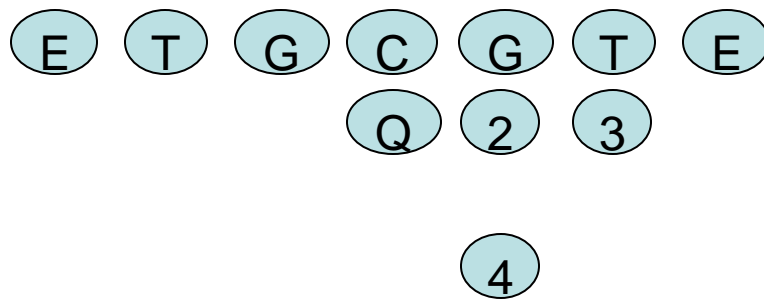

2006

Jeff Teed

Bomber Offense

- The Bomber Offense was the offense we used to go 40-5 over 5 years
- Used to over load one side of the line
- You can run and pass from this formation

Blocking

- Uses the GOOB Blocking Philosophy
- G – block playside Gap
- O – block man directly on you
- O – block man over you (LB)
- B – block back side (either DL or LB)

Hole Numbering

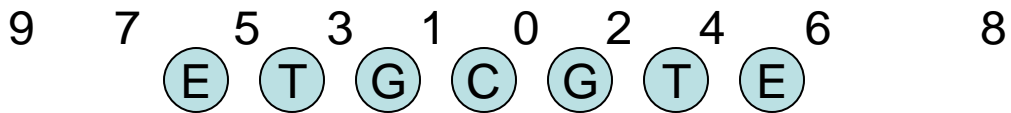

Plays

- Bomber Right 2
- Bomber Right 3
- Bomber Right 4
- Bomber Right 28 Toss
- Bomber Right 38 Toss
- Bomber Right 48 Toss
- Bomber Right 18 Sweep
- Bomber Right 18 Sweep Pass
- Bomber Right 17 Bootleg
- Bomber Right 17 Bootleg Pass
- Bomber Right 23 Counter
- Bomber Right 33 Counter
- Bomber Right 43 Counter
- Bomber Right Pop Pass
- Bomber Right 17 Bootleg Reverse
- Bomber Right 17 Bootleg Reverse Pass

Bomber Right 2

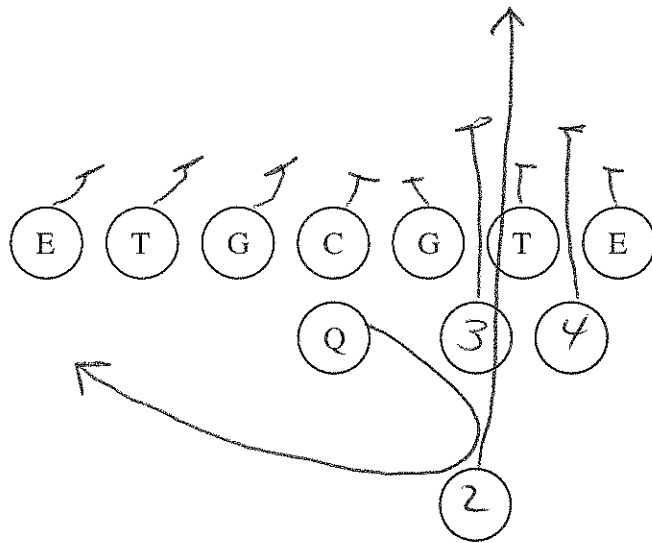

Bomber Right 3

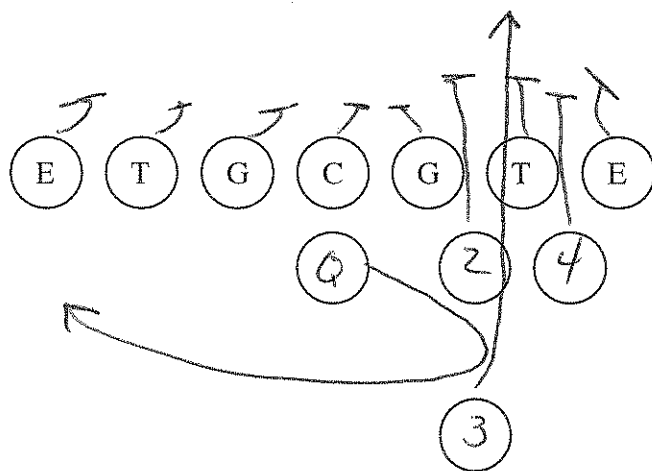

Bomber Right 4

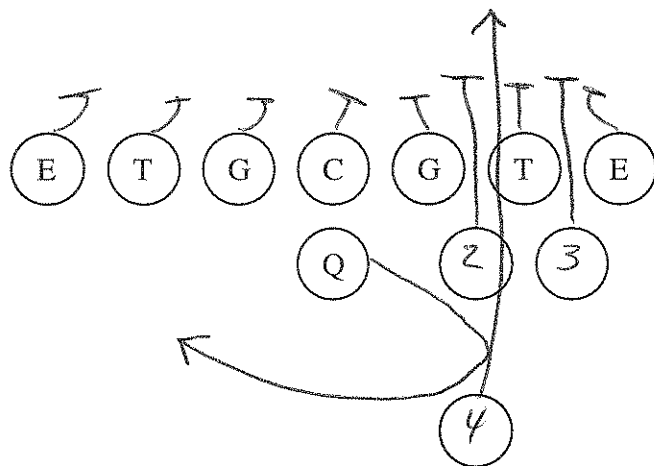

Bomber Right 28 Toss

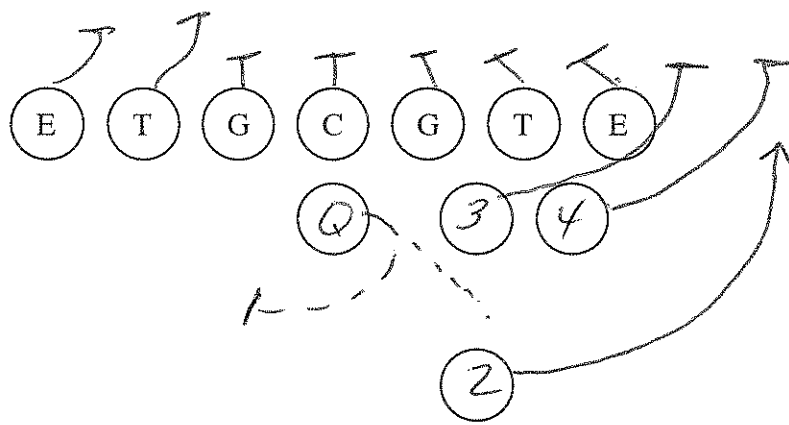

Bomber Right 38 Toss

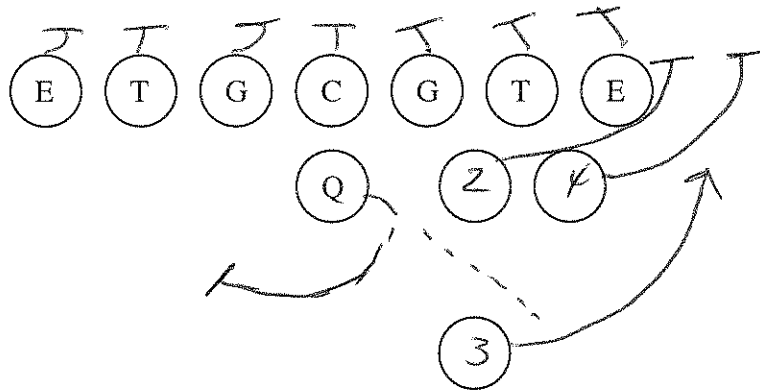

Bomber Right 48 Toss

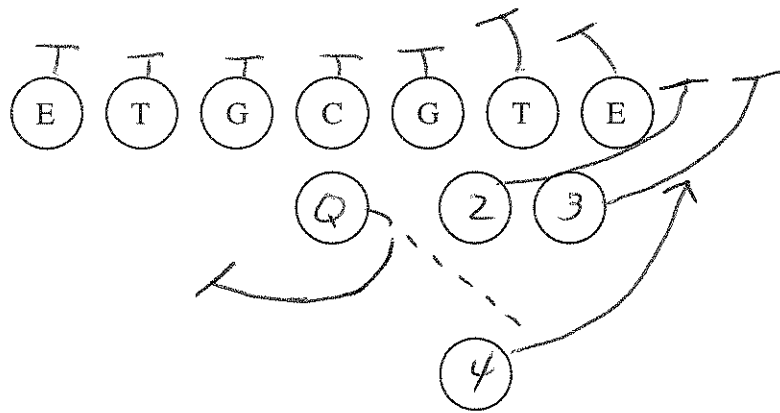

Bomber Right 18 Sweep

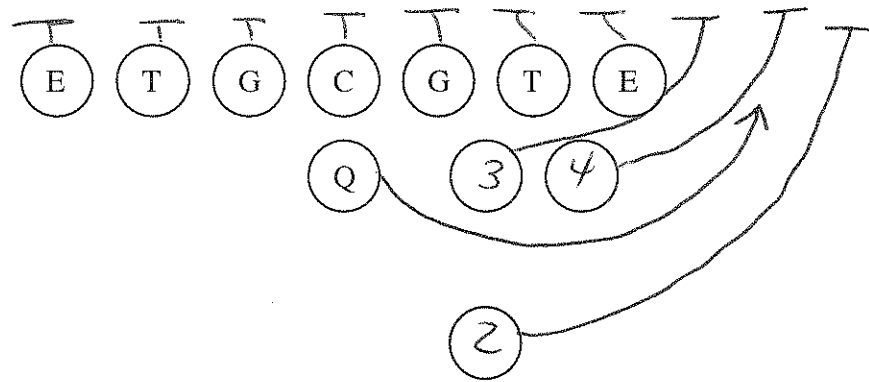

Bomber Right 18 Sweep Pass

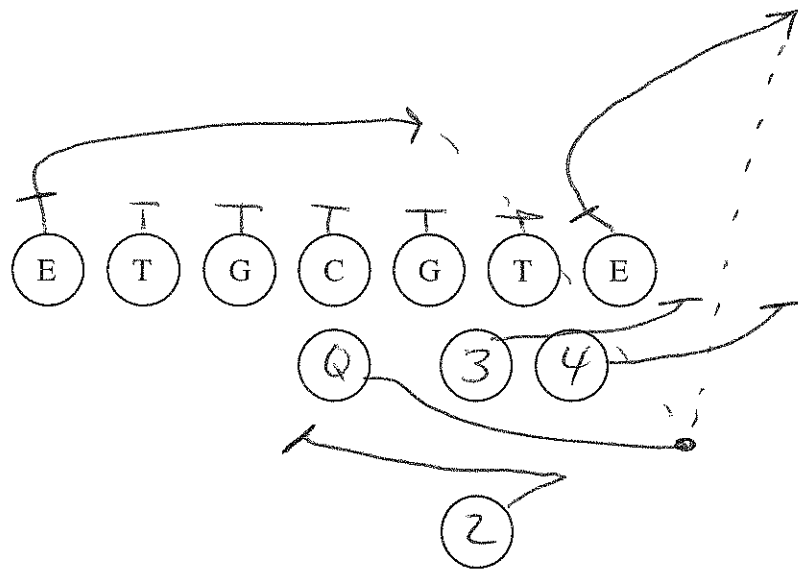

Bomber Right 17 Bootleg

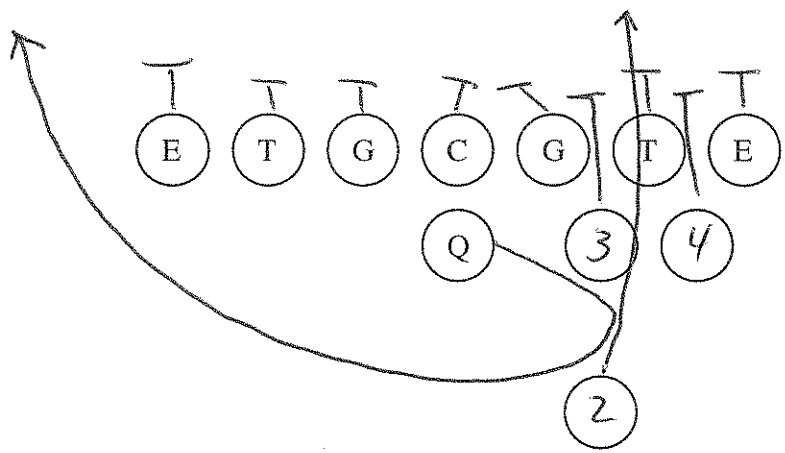

Bomber Right 17 Bootleg Pass

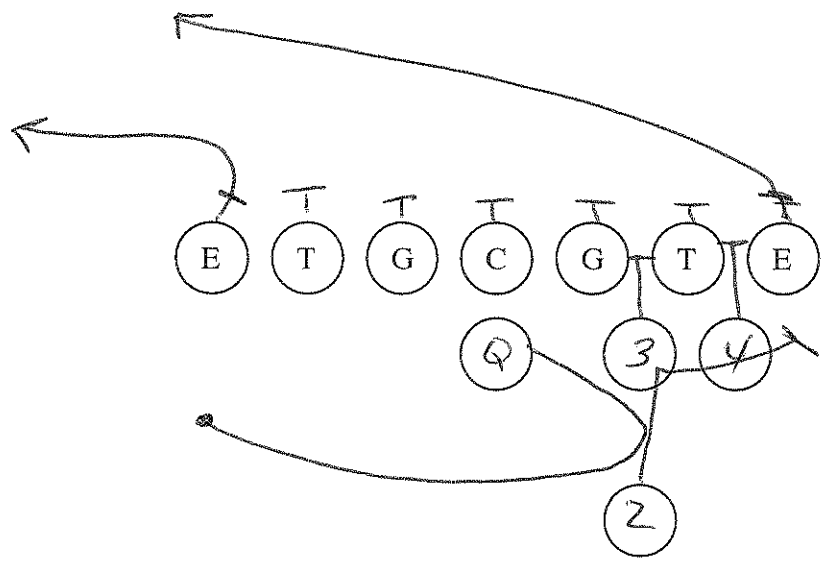

Bomber Right 23 Counter

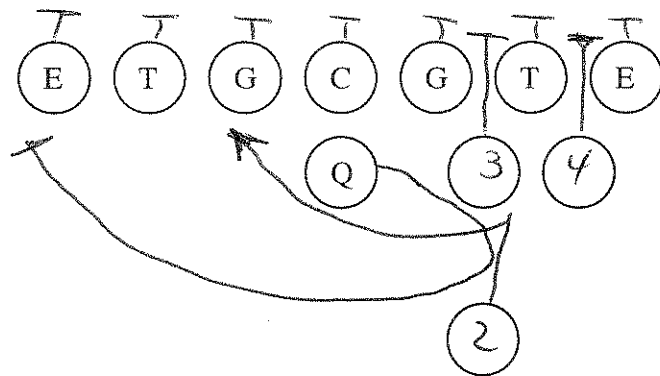

Bomber Right 33 Counter

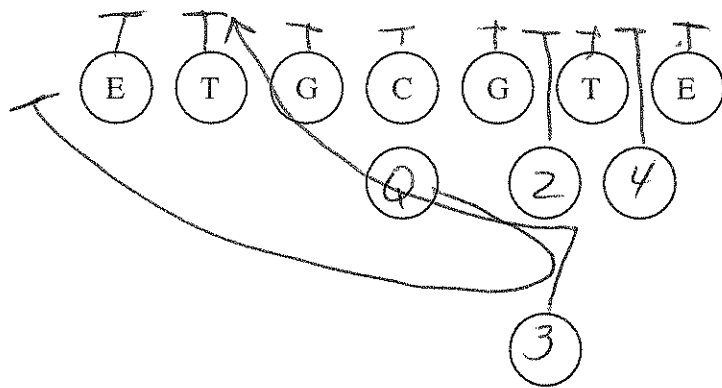

Bomber Right 43 Counter

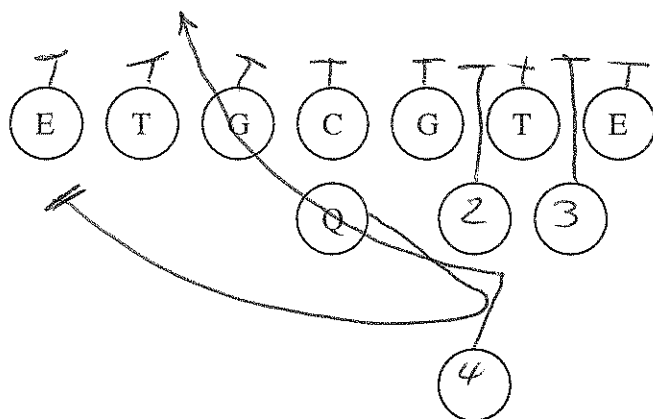

Bomber Right Pop Pass

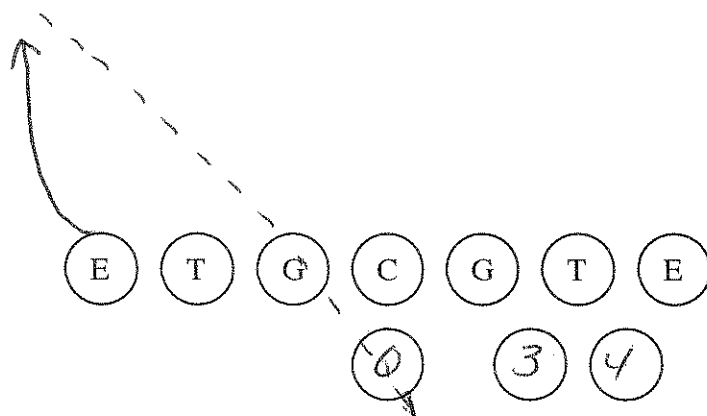

* NOTE *

GREAT PLAY AFTER
POUNING THE BALL TO
THE RIGHT 6-8 TIMES

(2)

Bomber Right 17 Bootleg Reverse

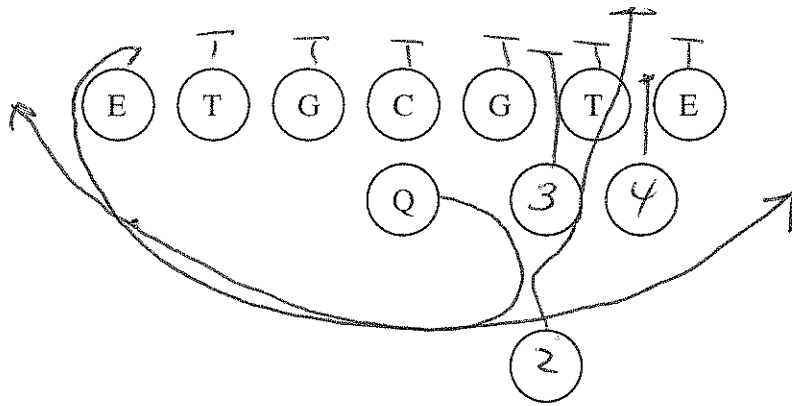

Bomber Right 17 Bootleg Reverse Pass

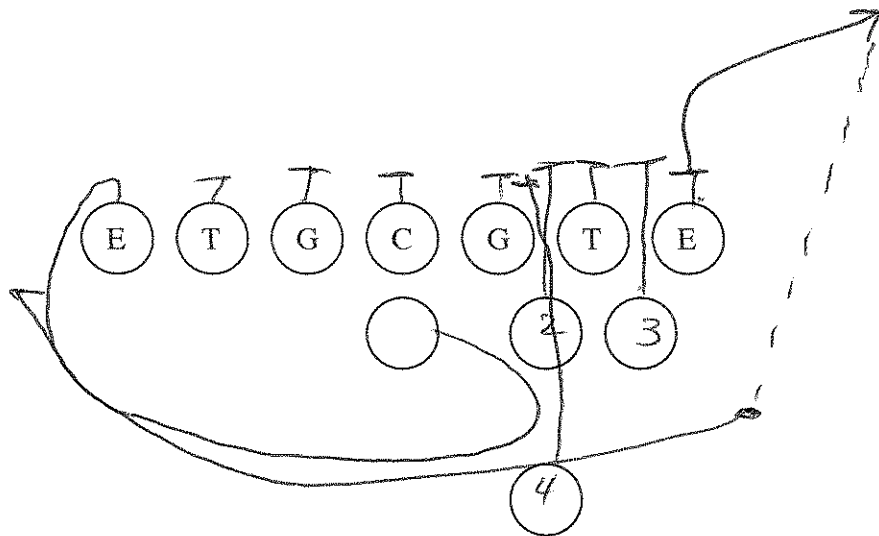

* NOTE *

THESE PLAYS WORK WELL BUT NEED TIME